

Model: HS-67Q

Thank you for using TKOKO product. TKOKO product is manufactured in accordance with ISO9000 standard. And it is widely used in hotel, shopping mall, school, and recreation facilities.

FEATURES:

- Dual cone with excellent sound.
- Compact and fashionable appearance.
- ABS.resin enclosure.
- Easy to install.
- Durable.

SPECIFICATIONS:

Model	HS-67Q
Rated power	7.5W/15W
Input voltage	100V
Sensitivity	106±2dB
Frequency response	250-7KHz
Product size	222x232x166mm
Weight	1.36kg

SIZE AND INSTALLATION: (unit:mm)

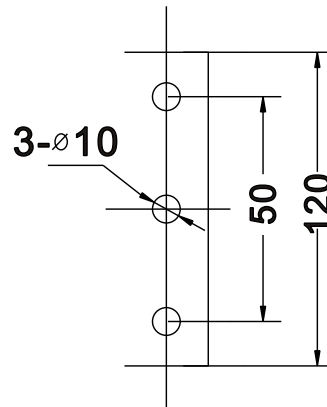
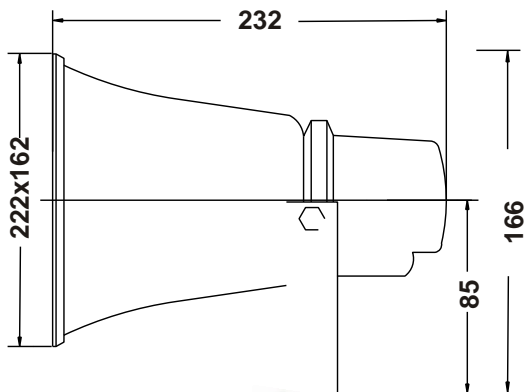

8ohm	6
N.C 15W	5
15W 7.5W	4
7.5W 3.75W	3
3.75W 1.9W	2
1.9W 0.95W	1
100V 70V	

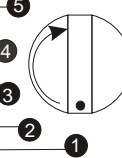



POINT SPEAKER

Model: HS-68Q

Thank you for using TKOKO product. TKOKO product is manufactured in accordance with ISO9000 standard. And it is widely used in hotel, shopping mall, school, and recreation facilities.

FEATURES:

- Dual cone with excellent sound.
- Compact and fashionable appearance.
- ABS.resin enclosure.
- Easy to install.
- Durable.

SPECIFICATIONS:

Model	HS-68Q
Rated power	15W/30W
Line .input	100V/8 Ω
Sensitivity	112±2dB
Frequency response	250-10KHz
Product size	285x280x227mm
Weight	1.8kg

SIZE AND INSTALLATION: (unit:mm)

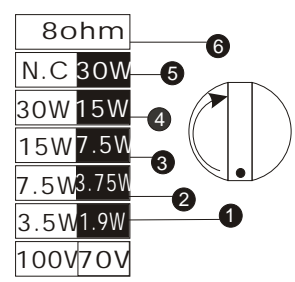
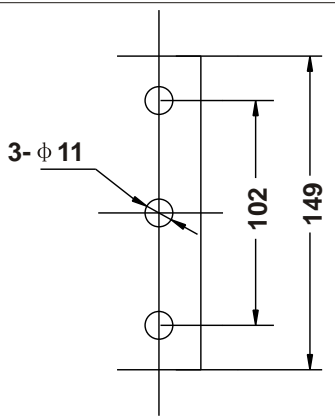
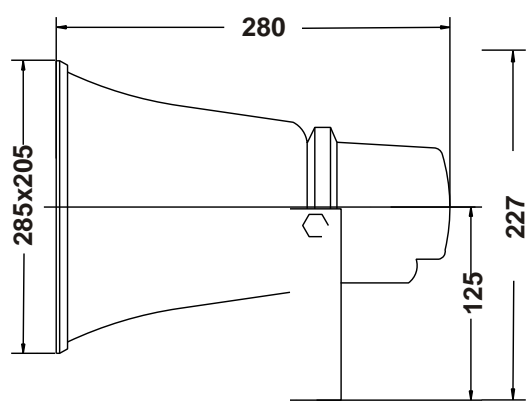

Note: Specifications are subject to change without notice